

CIRCULAR VIBRATING SCREEN

Technical data sheet

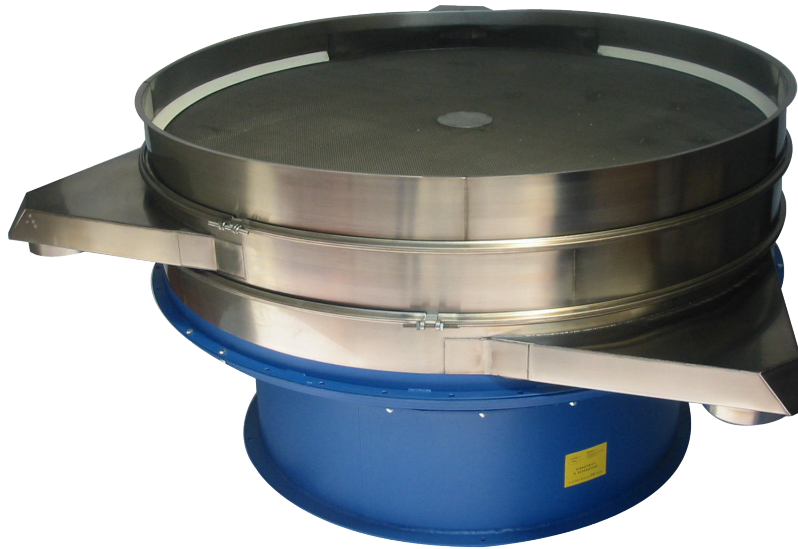

Silokonsult



Description

Companies increasingly need to treat their products, to ensure perfect quality. With its circular vibrating screens, ERIMAKI allows to meet this need.

Thanks to the simple adjustment of counterweights on the motor axis and to the three-dimensional vibration they generate, our circular vibrating screens allow to sieve, classify, dedust and filter a very wide range of products, achieving good results even with fine products.

The vibrating motion of the screen runs both horizontally and vertically and can be adjusted in both directions. The distinguishing feature of the ERIMAKI vibrating screen is the possibility to easily and quickly alter the vibrating movement and, as a consequence, the behaviour of the material to be sieved. By installing an inverter, besides, you can also change the vibration speed. This provides great flexibility of use, with both solid and liquid products.

The ERIMAKI vibrating screens require no special installation structures, as the upper section transmits no vibration to the base, which as a consequence may even be equipped with wheels. Thanks to the simplicity of their design, besides, the vibrating screens can also be disassembled very quickly for cleaning or mesh replacement.

On each vibrating screen you can install 1 to 4 separation stages, thus getting from 2 to 5 product fractions. The screen may be made of carbon steel or stainless steel, and equipped with different optional accessories.

The ERIMAKI vibrating screens provide good results and are easy to use, at truly competitive costs. The wide range of models (from Ø 400 to Ø 2200 mm) can meet any type of requirement. Besides manufacturing and selling screens and circular vibrating screens, sieves and electrical sieving machines, rotary separators and static separators, tumbler screens and direct discharge screens, our company also offers a sieving trial at our in-house laboratory. As an alternative it provides prospective customers with trial equipment, directly at their premises.

CIRCULAR VIBRATING SCREEN

Technical data sheet



Operation

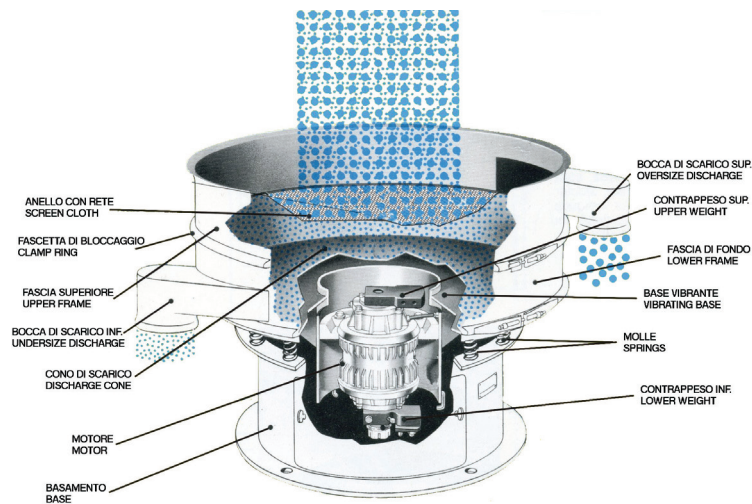

Product distribution on the mesh

- Straight-line distribution
- Normal spiral distribution
- Various spiral distribution
- Centripetal spiral distribution

Fields of application

- Solid and liquid materials

Accessories

- Self-cleaning ball system
- Self-cleaning kleener system
- Self-cleaning brush system
- Cover
- Meshes

Silokonsult

CIRCULAR VIBRATING SCREEN

Tecnical data sheet



Silokonsult

Dimensions

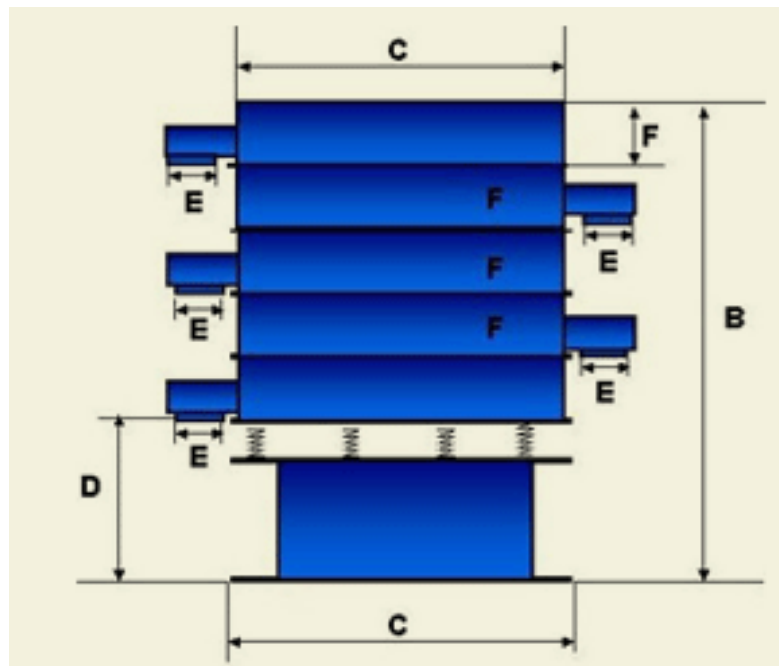

Diameter 400

Meshes	A	B	C	D	E	F
N. 1	438	700	470	460	80	120
N. 2	438	820	470	460	80	120
N. 3	438	940	470	460	80	120
N. 4	438	1060	470	460	80	120

Diameter 600

Meshes	A	B	C	D	E	F
No. 1	600	900	510	560	150	165
No. 2	600	1065	510	560	150	165
No. 3	600	1230	510	560	150	165
No. 4	600	1395	510	560	150	165

Diameter 900

Meshes	A	B	C	D	E	F
No. 1	900	900	810	560	150	165
No. 2	900	1065	810	560	150	1650
No. 3	900	1230	810	560	150	165
No. 4	900	1395	810	560	150	165

ERIMAKI SNC di Cecilia Janni & C. - Via Timavo 36, 20037 Paderno Dugnano (Milan) - Italy

Phone +39 02.99044723 - +39 02.99044734 | Fax +039 02.99044729 | info@erimaki.it | www.erimaki.it

C.C.I.A.A 1169255 Codice Fiscale 07604340153 Partita IVA 02537230969

CIRCULAR VIBRATING SCREEN

Tecnical data sheet



Diameter 1200

Meshes	A	B	C	D	E	F
No. 1	1200	900	940	560	204	165
No. 2	1200	1065	940	560	204	165
No. 3	1200	1230	940	560	204	165
No. 4	1200	1395	940	560	204	165

Diameter 1500

Meshes	A	B	C	D	E	F
N. 1	1490	900	1080	560	204	165
N. 2	1490	1065	1080	560	204	165
N. 3	1490	1230	1080	560	204	165
N. 4	1490	1395	1080	560	204	165

Diameter 1800

Meshes	A	B	C	D	E	F
No. 1	1800	900	1380	560	204	165
No. 2	1800	1065	1380	560	204	165
No. 3	1800	1230	1380	560	204	165
No. 4	1800	1395	1380	560	204	165

Diameter 2200

Meshes	A	B	C	D	E	F
No. 1	2200	1450	1800	960	204	240
No. 2	2200	1690	1800	960	204	240
No. 3	2200	1930	1800	960	204	240
No. 4	2200	2170	1800	960	204	240

Silokonsult
PROCESSTEKNIK SWEDEN AB

Kämpagatan 1
SE-532 36 Skara
+46 511 10365
info@silokonsult.se
www.silokonsult.se