

Diverter Valves

VAD

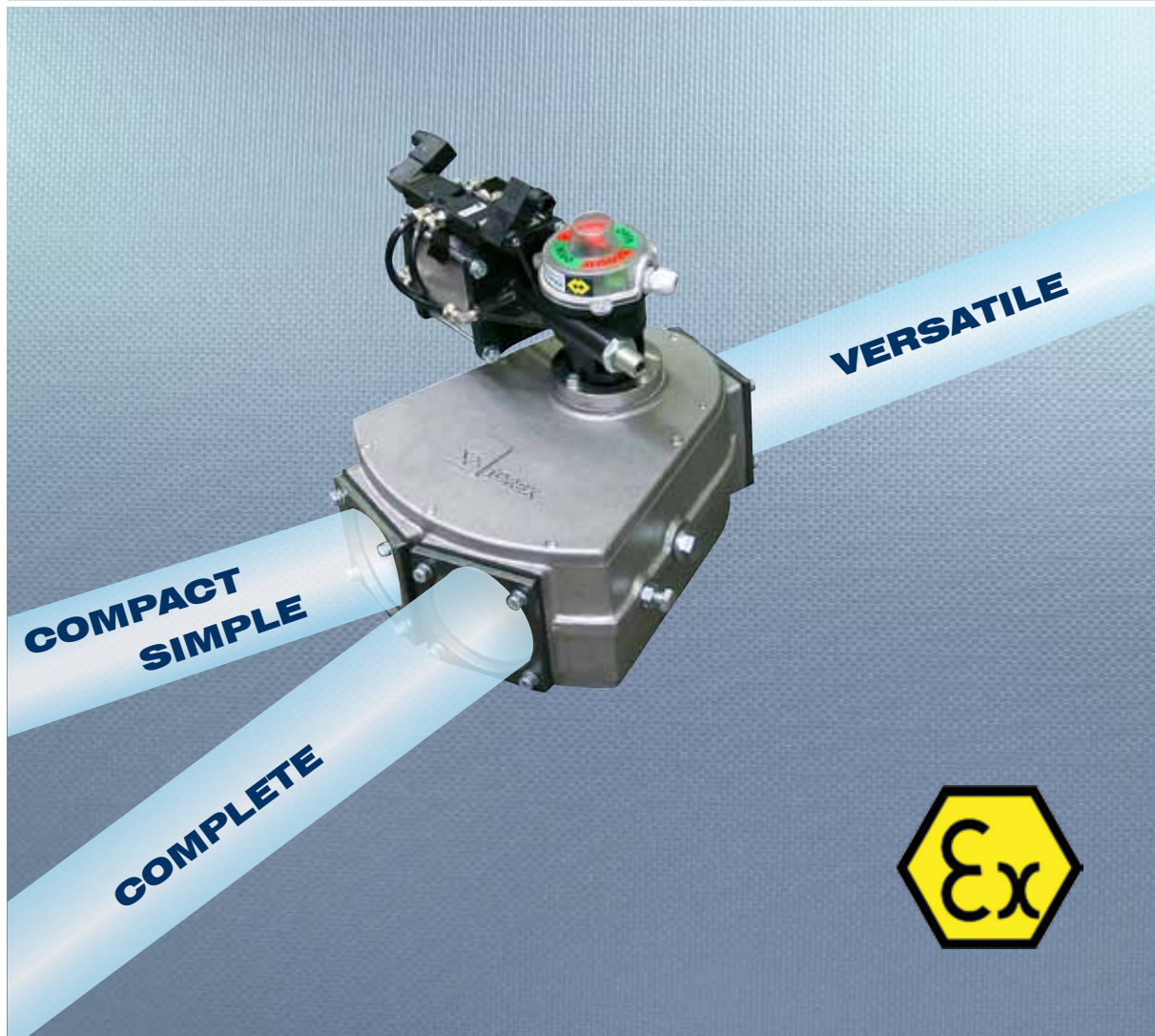

THE MOST COMPACT, SIMPLE AND VERSATILE DIVERTER VALVE AT A LOWER COST

Manufactured entirely in aluminium with the option of nickel-plating, the valve is activated either manually or by means of a pneumatic or an electric motor-operated actuator.

Activation of the actuator makes it possible to change the direction of the material flow.

Features

VALVE

- Cast aluminium alloy casing
- Various actuators in different voltages
- Low friction gaskets
- Operating temperature: - 20°C to 80°C (-4°F to 176° F)
- Operating pressure: max. 2.5 bar (36 PSI)
- Aluminium casting or nickel plated versions available both with ATEX certification for Group II Cat. 1D/3D c T 135°C on request

ACTUATOR

Pneumatic Actuator

- Voltage supply: 24 V AC, 24 V DC, 110 V AC, 230 V AC

Electric Actuators

- Voltage supply: 230/400 V AC 50/60 Hz

Manual Actuator

- Manually operated

Overall Dimensions

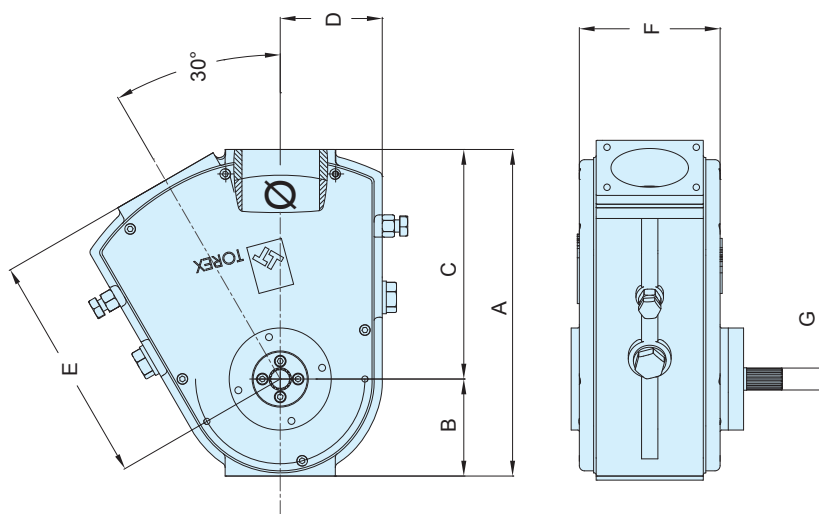

							ACTUATOR CONNECTION	
VAD	Ø	A	B	C	D	F	G	
50	45	245	75	170	80	122	CP101 - AE04011 - CM4	
80	76	320	95	225	100	135		
100	96	345	105	240	110	155		

Benefits

- ✓ **Lightweight and compact design**
- ✓ **Easy to install**
- ✓ **Maintenance-friendly**

1 Low friction gaskets



- Minimum pressure drop inside conveying duct

2 Adjustable and Easy to Use as Diverter or Converter

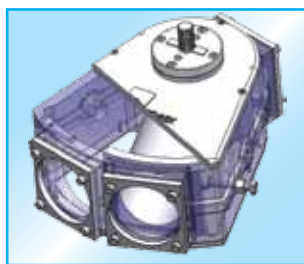

- Actuator assembly on both sides of the casing
- Square Counter-Flanges in carbon steel or 304 Stainless Steel as standard assures system compatibility

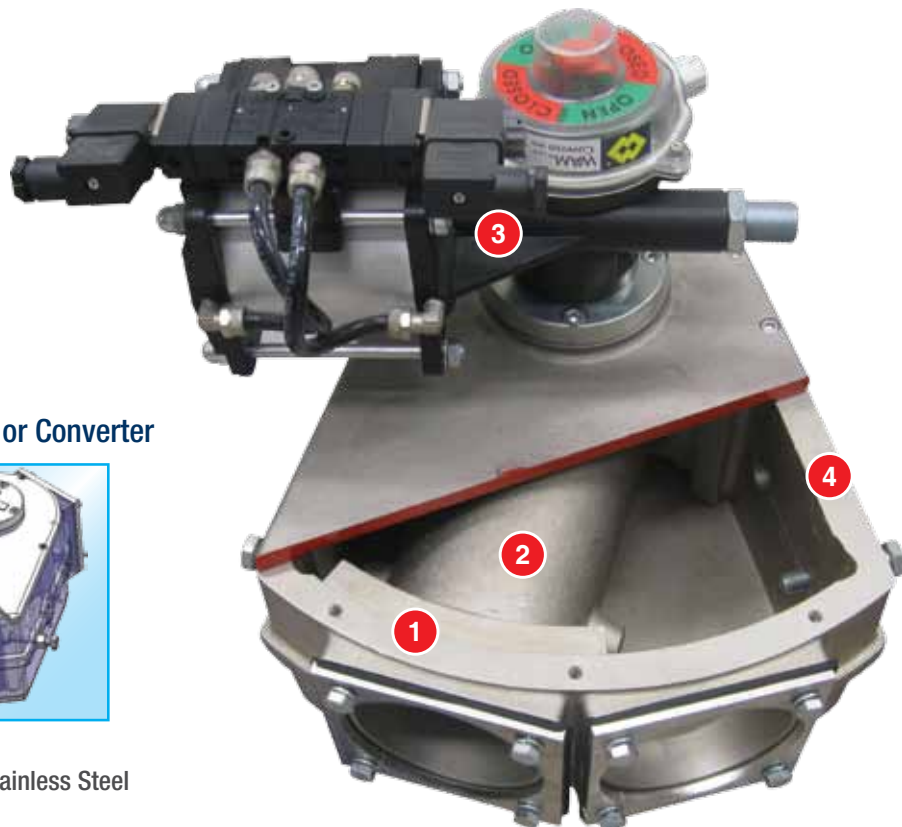

3 Various type of actuators



Pneumatic Actuator CP101
Operating Pressure: 2-7 bar



Electric Actuator AE40A11
Power: 0.18 kW
Protection: IP 55
Voltage: 50 Hz - 230/400 Volt



Manual Actuator CM4

4 Nickel Plated Version



- Increased resistance to corrosion
- Higher surface hardness
- Food Grade Nickel Coating available

Accessories

Inlet/Outlet Connection Pipes



- Zinc coated mild steel
- 304 Stainless Steel

Application



VAD Diverter Valves are suitable for handling any type of powdery or granular material in pneumatic conveying systems.



063001497 February 2013 Rights reserved to modify technical specifications.



Silokonsult
PROCESSTEKNIK SWEDEN AB

Kämpagatan 1
SE-532 36 Skara
+46 511 10365
info@silokonsult.se
www.silokonsult.se



www.wamgroup.com