



SKIOLD DAMAS SIGMA



SKIOLD MAKES THE DIFFERENCE!

SKIOLD DAMAS SIGMA

Function

The raw material (1) is conveyed to the screen drums (3) via the distributor (2). The drums rotate in a planetary movement, i.e. around their own axis (4) while the drum axes rotate around the centre of the machine at the same time. The centrifugal force flings the grains towards the screen walls (5) and separation is achieved when the smaller grains pass through the screens. Large and coarse particles are removed on the inner screens. The grain is collected in channels (6) at the periphery of the machine and discharged from the outlets (7). The clean material leaves the machine through the outlet (10) of the aspirator (8). Light particles (9) are drawn by a fan to a cyclone or similar dust collector.

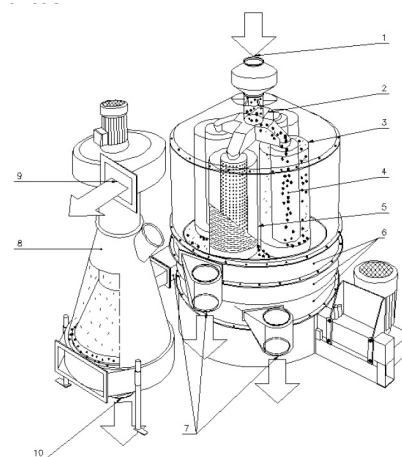

TECHNICAL SPECIFICATIONS

Motors	752 A	753 A	754 A	1004 A	1004 B	756 A	756 2A	1006 A	1006 2A	1008 A	1008 2B
Main motor (kW):	11	15	18.5	18.5	18.5	18.5	18.5	18.5	18.5	30	30
Air part (kW):	0.37	0.37	0.37	0.37	0.37	0.37	2×0.37	0.37	2×0.37	0.37	2×0.37
Fan (kW):	5.5	5.5	5.5	5.5	7.5	5.5	2×5.5	5.5	2×5.5	5.5	2×5.5
Rotary seal (kW):	0.55	0.55	0.55	0.55	0.55	0.55	2×0.55	0.55	2×0.55	0.55	2×0.55

Air systems	752/754 A	1004 A	1004 B	756/1006 A	756/1006 2A	1008 A	1008 2B
Open air system I-III (1000 m³/h):	3-5	3-5	5-7	3-5	2×3-5	3-5	2×5-7
Recycling air system IV (1000 m³/h):	1.2-1.5	1.2-1.5	1.5-2.0	1.2-1.5	2×1.2-1.5	1.2-1.5	2×1.5-2.0
Cyclone type	UC-110	UC-110	UC-140	UC-110	2×UC-110	UC-110	2×UC-140

· Type A uses aspirator type 80 · Type B uses aspirator type 120

GUIDING CAPACITIES

Precleaning	752 A	753 A	754 A	1004 A	1004 B	756 A	756 2A	1006 A	1006 2A	1008 A	1008 2B
Wheat, 18% H ₂ O (t/h):	45	65	85	85	110	85	130	85	165	85	220
Barley, 18% H ₂ O (t/h):	40	60	80	80	100	80	120	80	150	80	200
Maize, 35% H ₂ O (t/h):	25	35	45	45	55	45	70	45	80	45	110
Maize, 45% H ₂ O (t/h):	20	30	40	40	50	40	60	40	75	40	100
Rapeseed, 17% H ₂ O (t/h):	30	50	60	60	80	60	100	60	120	60	160
Rice/sunflower, 18% H ₂ O (t/h):	20	30	40	40	50	40	60	40	75	40	100
Intervention cleaning											
Barley, 14% H ₂ O (t/h):	20	30	40	50	50	60	60	75	75	80	100
Malting barley											
20% separation (t/h):	4	6	8	10	10	12	12	15	15	20	20
15% separation (t/h):	6	9	12	15	15	18	18	22	22	30	30
10% separation (t/h):	10	15	20	25	25	30	30	37	37	50	50
Industrial cleaning											
Rapeseed, 9% H ₂ O (t/h):	15	25	30	40	40	40	50	40	60	40	80
Rapeseed, 17% H ₂ O (t/h):	10	15	20	25	25	30	30	30	40	30	50
Sunflower, 9% H ₂ O (t/h):	20	30	40	45	45	45	55	45	70	45	90
Sunflower, 15% H ₂ O (t/h):	16	24	30	35	35	35	40	35	50	35	70